

# AUTOMATIC LABELLER

## Pk-150 Evo

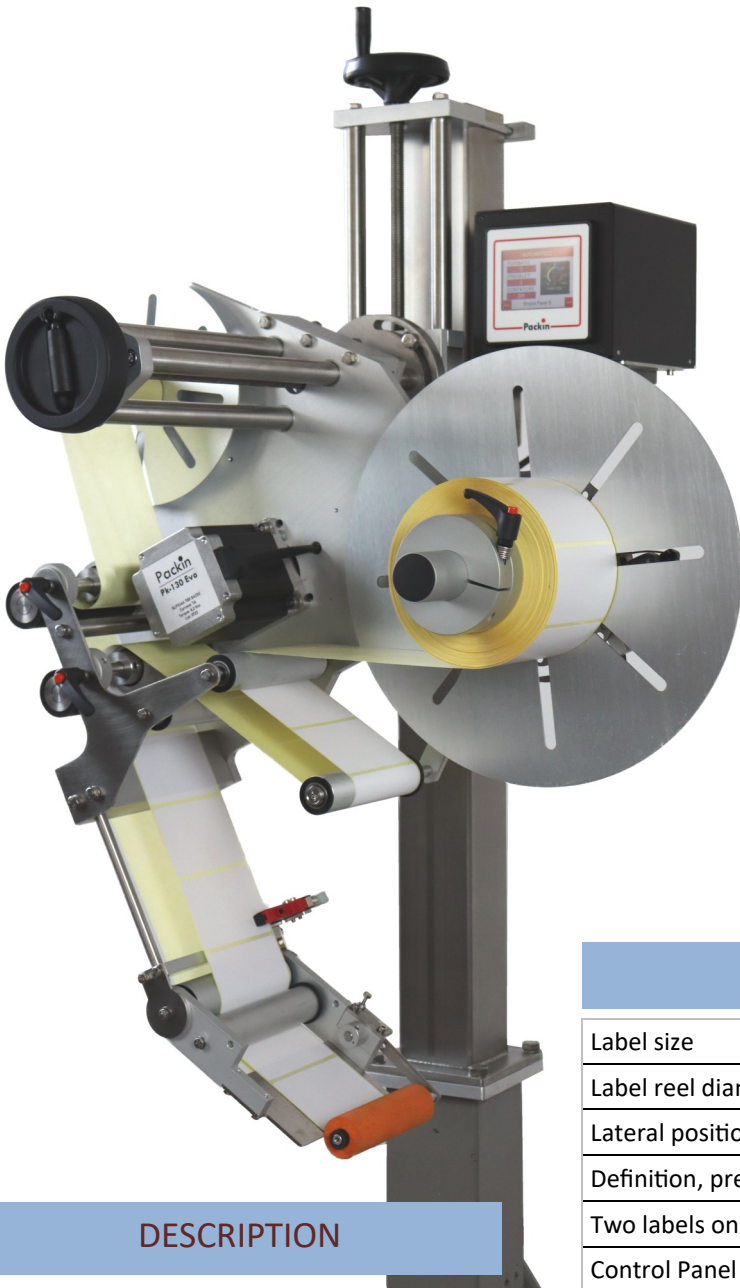

### DESCRIPTION

and 2D (QRCode), monochrome images, logos. The markers are available with or without a 7" color touch-screen control panel for 12.7 or 50.8mm print areas. with 1 or 2 heads. The inkjet marker offers the possibility of using various types of inks for almost all types of labels. Furthermore, it does not limit the speed of the machine which can thus exploit the full potential of the 60 m/min. An exclusive system allows label position, start and cycle adjustments to be made with the machine stopped.

### DESCRIPTION

Pk-150 Evo with 350mm reel holder, up to 60 m/min, up to 200 pcs/minute, the main features of this machine with industrial characteristics. Pk-150 Evo is a fast automatic labelling machine for self-adhesive labels which easily finds its place on production lines as in existing machinery thanks to the compactness of its design and also to the separate control unit which reduces its overall dimensions. Pk-150 Evo comes complete with all the functions needed to control from and to remote machines, encoder, signaling light, input, pre and end reel alarms, paper breakage, missing label recovery, two labels on one product, automatic speed (encoder), tandem functions with 2 PK-150 Evo heads for continuous machining. It can be equipped with HP TIJ2.5 micro-character technology high-definition inkjet markers for marking dates, lots, alphanumeric data, progressive or decreasing numbering, 1D barcode

### TECHNICAL FEATURES

Label size	From 20x20 to 150x620 mm
Label reel diameter	Int 45/70 Ext fup to 350mm
Lateral positioner	Yes, integrated with hand lever
Definition, precision	+/- 1mm
Two labels on product	Yes
Control Panel	Color Touch-screen 100 program
Inkjet marker encoder	Yes, optional 12.7 or 50.8mm
Photocell for transparent labels	Yes, optional
Speed	Up to 60 mt/min
Frequency	Up to 200 pz/min.
Power Supply	220/110 Vac 500 W
Alarms	Roll end, paper break, roll pre-end, In/Out, mach. Ext.
Weight	35 Kg
Dimensions LxPxH	58x48x70 cm

**Packin**

## TECHNICLE CHARACTERISTICS

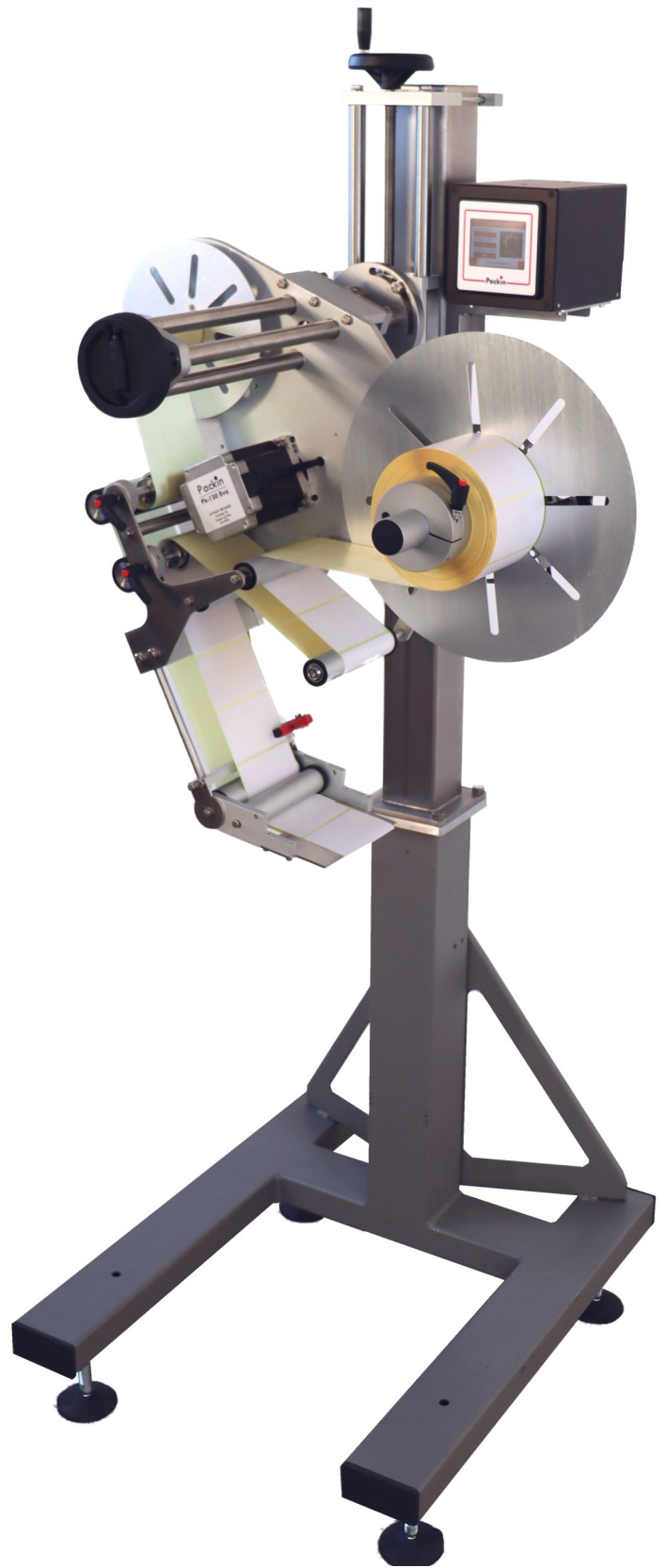
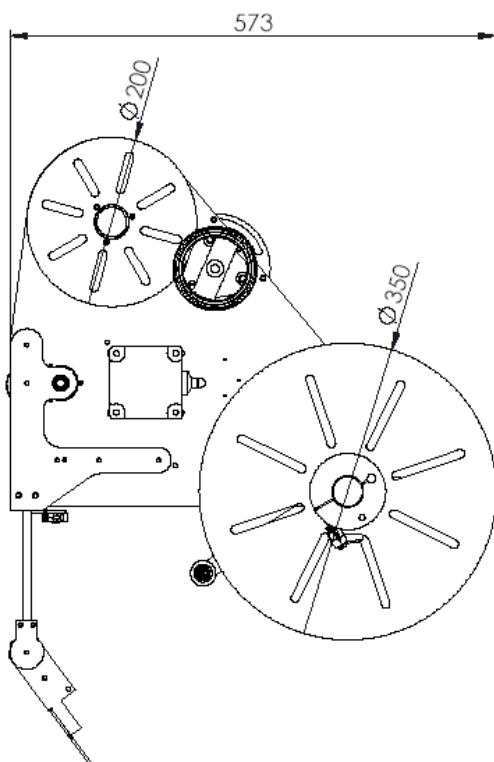
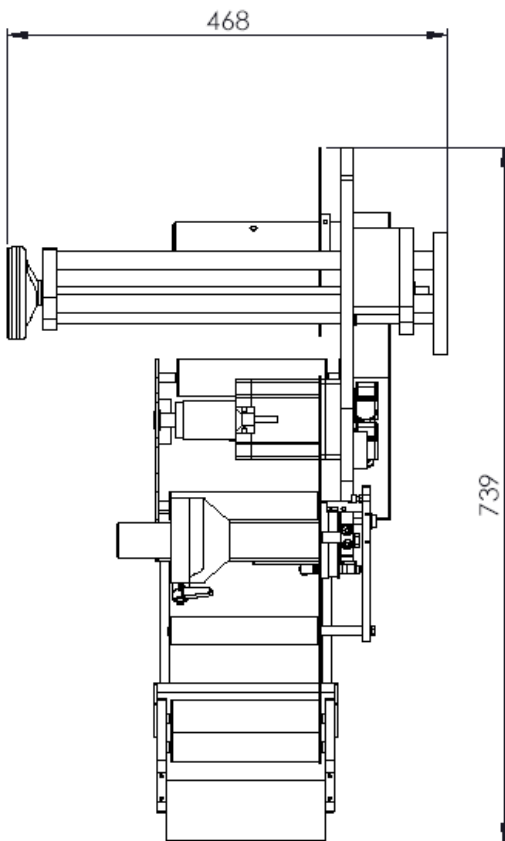

Packin